

AWWA

По вопросам продаж и поддержки обращайтесь:

Алматы (7273)495-231	Казань (843)206-01-48	Новокузнецк (3843)20-46-81	Смоленск (4812)29-41-54
Архангельск (8182)63-90-72	Калининград (4012)72-03-81	Новосибирск (383)227-86-73	Сочи (862)225-72-31
Астрахань (8512)99-46-04	Калуга (4842)92-23-67	Омск (3812)21-46-40	Ставрополь (8652)20-65-13
Барнаул (3852)73-04-60	Кемерово (3842)65-04-62	Орел (4862)44-53-42	Сургут (3462)77-98-35
Белгород (4722)40-23-64	Киров (8332)68-02-04	Оренбург (3532)37-68-04	Тверь (4822)63-31-35
Брянск (4832)59-03-52	Краснодар (861)203-40-90	Пенза (8412)22-31-16	Томск (3822)98-41-53
Владивосток (423)249-28-31	Красноярск (391)204-63-61	Пермь (342)205-81-47	Тула (4872)74-02-29
Волгоград (844)278-03-48	Курск (4712)77-13-04	Ростов-на-Дону (863)308-18-15	Тюмень (3452)66-21-18
Вологда (8172)26-41-59	Липецк (4742)52-20-81	Рязань (4912)46-61-64	Ульяновск (8422)24-23-59
Воронеж (473)204-51-73	Магнитогорск (3519)55-03-13	Самара (846)206-03-16	Уфа (347)229-48-12
Екатеринбург (343)384-55-89	Москва (495)268-04-70	Санкт-Петербург (812)309-46-40	Хабаровск (4212)92-98-04
Иваново (4932)77-34-06	Мурманск (8152)59-64-93	Саратов (845)249-38-78	Челябинск (351)202-03-61
Ижевск (3412)26-03-58	Набережные Челны (8552)20-53-41	Севастополь (8692)22-31-93	Череповец (8202)49-02-64
Иркутск (395)279-98-46	Нижний Новгород (831)429-08-12	Симферополь (3652)67-13-56	Ярославль (4852)69-52-93
Россия (495)268-04-70	Киргизия (996)312-96-26-47	Казахстан (7172)727-132	

Эл. почта dya@nt-rt.ru || Сайт: <https://davanflowtek.nt-rt.ru/>

AWWA metal seated gate valve with flange



AWWA metal seated gate valve with flange, which can be used in water supply and drainage project.

Details

AWWA metal seated gate valve with flange technical specification:

Nominal Diameter: DN50–DN600

Nominal Pressure: 10Bar/16Bar

Design Standard: MSS SP-70/BS5150/BS5163/DIN3352/JIS B2043

FTF Dimension: ANSI B16.10/BS5150 SERIES 3/DIN3302 F4/JIS B2002

Flange Connection: ASME B16.1 CL125/ASME B16.5 CL150/

DIN 2501 PN10-16/EN1092 PN10-16 /JIS B2212 10K

Inspection and Test: ISO 5208/EN 12266-1/ API598

The main advantages of gate valve include:

1. The fluid resistance of the valve is small. Because the valve body of gate valve is straight-through type and the flow of the medium doesn't change direction, the fluid resistance of it is small compared with other kinds of valves.
2. The sealing performance is better than that of other shut-off valve. The opening and closing of it is more conveniently.
3. The range of applications is more wider. In addition to steam, oil and other media, it can be used in medium containing granular solid and with a large viscosity. It can also be used as air-venting valve and low vacuum system valve.
4. Gate valve has dual flow directions. It's not subject to the flow directions of the medium. Therefore, it is suitable for use in pipeline where the medium may change the flow direction. It is also easy to install.

AWWA metal seated gate valve with flange Material List

1. Body/Bonnet Cast Iron ASTM A126 CLB/JIS G 5501 FC20
2. Wedge Cast Iron ASTM A126 CLB/JIS G 5501 FC20
3. Stem Stainless Steel JIS SUS420J1
4. Seat Cast Bronze ASTM B62/JIS G 5511 BC6
5. Wedge Face Rings Cast Bronze ASTM B62/JIS G 5511 BC7
6. Handwheel Cast Iron ASTM A126 CLB/JIS G 5501 FC20
7. Packing Gland Cast Iron ASTM A126 CLB/JIS G 5501 FC20
8. Packing Graphite
9. Stem Nut Ductile Iron ASTM A536 65-45-12/JIS G 5502 FCD450
10. Yoke Cast Iron ASTM A126 CLB/JIS G 5501 FC20
11. Gasket Graphite

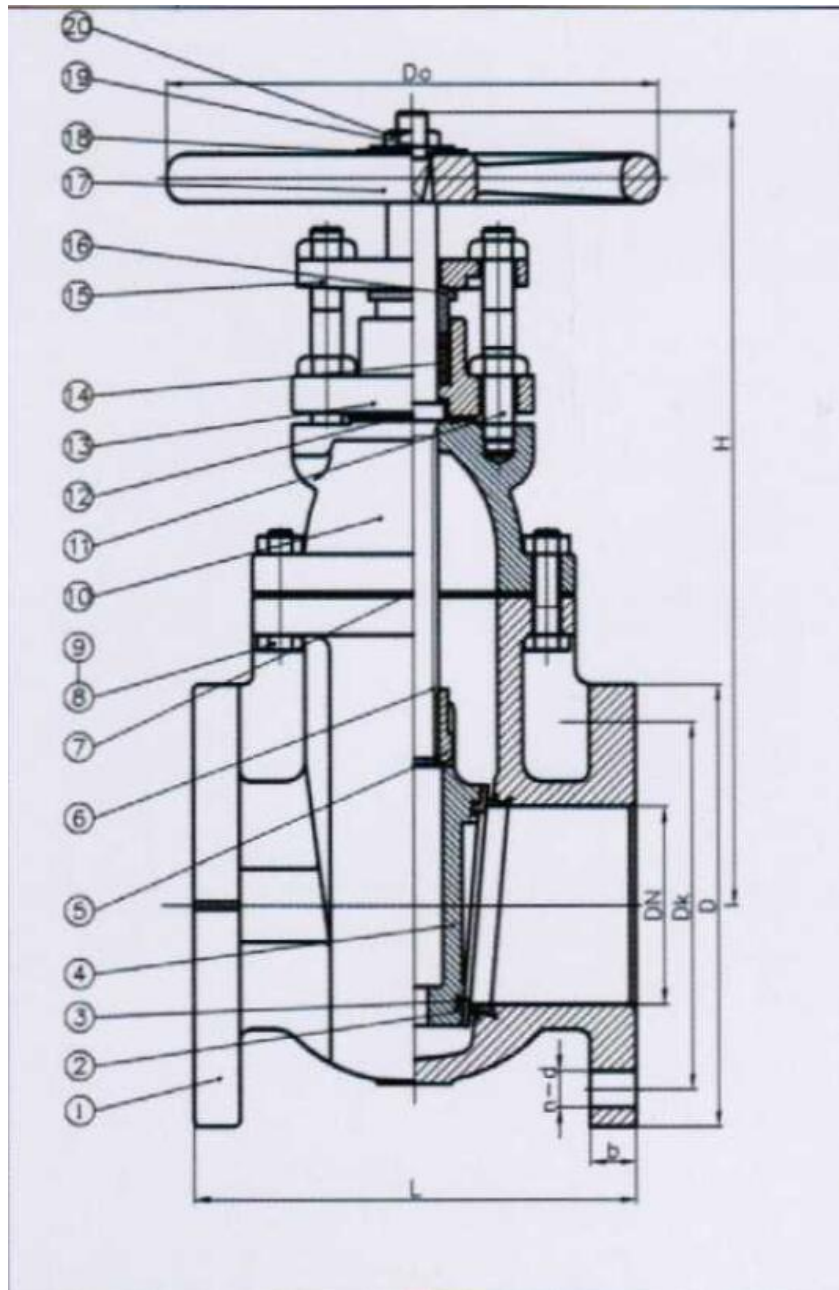

DIMENSIONS IN INCHES AND MILLIMETRES							
DN	L	Dk	D	b	n-d	Do	H
2"	178	121	152	15.9	4-19	178	289
2.5"	190.5	140	178	17.5	4-19	178	323
3"	203.2	152.5	190	19.1	4-19	200	338
4"	228.6	190.5	228.6	23.5	8-19	254	411
5"	254	215.9	254	23.8	8-22	300	503
6"	266.7	241.3	279.4	25.4	8-22	300	558
8"	292	298.5	343	28.6	8-22	348	650
10"	330	362	406	30.2	12-25	400	770
12"	356	432	483	31.8	12-25	457	861
14"	381	476	533	35	12-29	508	991
16"	406	540	597	36.6	16-29	558	1058
18"	432	578	635	39.7	16-32	610	1206
20"	457	635	699	42.9	20-32	640	1276
24"	508	749	813	47.6	20-35	762	1466
30"	610	914	984	54	28-35	813	1845
36"	711	1086	1168	60.3	32-42	813	2124

No.	Part	Material	USA Standard
1	Body	Cast Iron	ASTM A126 CLASS B
2	Seat Rings	Cast Bronze	ASTM B62
3	Wedge Face Rings	Cast Bronze	ASTM B62
4	Wedge	Cast Iron	ASTM A126 CLASS B
5	Wedge Nut	Cast Brass	ASTM B62
6	Stem	Brass	ASTM B16
7	Body Gasket	Graphite	NON ASBESTOS
8	Bolts	Steel	ASTM A307 B
9	Nuts	Steel	ASTM A307 B
10	Bonnet	Cast Iron	ASTM A126 CLASS B
11	Gland Follower Bolts	Steel	ASTM A307 B
12	Stuffing Box Gasket	Graphite	NON ASBESTOS
13	Stuffing Box	Cast Iron	ASTM A126 CLASS B
14	Packing	Graphite	NON ASBESTOS
15	Gland Follower	Ductile Iron	ASTM A536 65-45-12
16	Packing Gland	Cast Brass	ASTM B584
17	Handwheel	Cast Iron	ASTM A126 CLASS B
18	Identification Plate	Aluminium	
19	Washer	Steel	ASTM A307 B
20	Handwheel Nut	Steel	ASTM A307 B

По вопросам продаж и поддержки обращайтесь:

Алматы (7273)495-231	Казань (843)206-01-48	Новокузнецк (3843)20-46-81	Смоленск (4812)29-41-54
Архангельск (8182)63-90-72	Калининград (4012)72-03-81	Новосибирск (383)227-86-73	Сочи (862)225-72-31
Астрахань (8512)99-46-04	Калуга (4842)92-23-67	Омск (3812)21-46-40	Ставрополь (8652)20-65-13
Барнаул (3852)73-04-60	Кемерово (3842)65-04-62	Орел (4862)44-53-42	Сургут (3462)77-98-35
Белгород (4722)40-23-64	Киров (8332)68-02-04	Оренбург (3532)37-68-04	Тверь (4822)63-31-35
Брянск (4832)59-03-52	Краснодар (861)203-40-90	Пенза (8412)22-31-16	Томск (3822)98-41-53
Владивосток (423)249-28-31	Красноярск (391)204-63-61	Пермь (342)205-81-47	Тула (4872)74-02-29
Волгоград (844)278-03-48	Курск (4712)77-13-04	Ростов-на-Дону (863)308-18-15	Тюмень (3452)66-21-18
Вологда (8172)26-41-59	Липецк (4742)52-20-81	Рязань (4912)46-61-64	Ульяновск (8422)24-23-59
Воронеж (473)204-51-73	Магнитогорск (3519)55-03-13	Самара (846)206-03-16	Уфа (347)229-48-12
Екатеринбург (343)384-55-89	Москва (495)268-04-70	Санкт-Петербург (812)309-46-40	Хабаровск (4212)92-98-04
Иваново (4932)77-34-06	Мурманск (8152)59-64-93	Саратов (845)249-38-78	Челябинск (351)202-03-61
Ижевск (3412)26-03-58	Набережные Челны (8552)20-53-41	Севастополь (8692)22-31-93	Череповец (8202)49-02-64
Иркутск (395)279-98-46	Нижний Новгород (831)429-08-12	Симферополь (3652)67-13-56	Ярославль (4852)69-52-93
Россия (495)268-04-70	Киргизия (996)312-96-26-47	Казахстан (7172)727-132	